

THE POWERLINE SERIES

Electric Fence Protection Dual Kit

12-00044

rev_2

Features

- Easy installation
- Equi-potential earthing system
- High surge capability
- Effective filtration

This protection kit provides an integrated approach to the protection of electrical fences. It provides surge and filtered protection for the incoming mains supply with an additional protector for earth potential equalization. A high voltage unit is supplied for the protection of energizer output terminals.



Specification	
Max. operating voltage	250VAC 50Hz
Max. discharge current	8kA(8/20)
Max. high voltage output	15kV DC
Response time	<25ns
Temperature range	-20°C to 70°C
Filtration (power only)	-50dB L-N, L-E, N-E
Standards compliance	IEC 61643-1, ANSI 662.1

Dimension

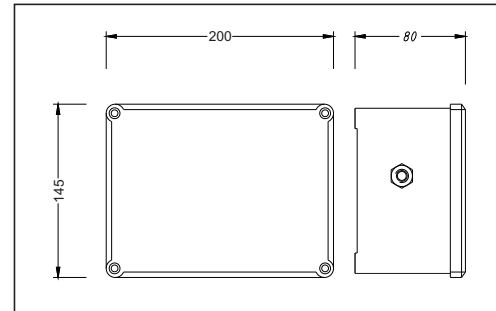

Wiring Diagram

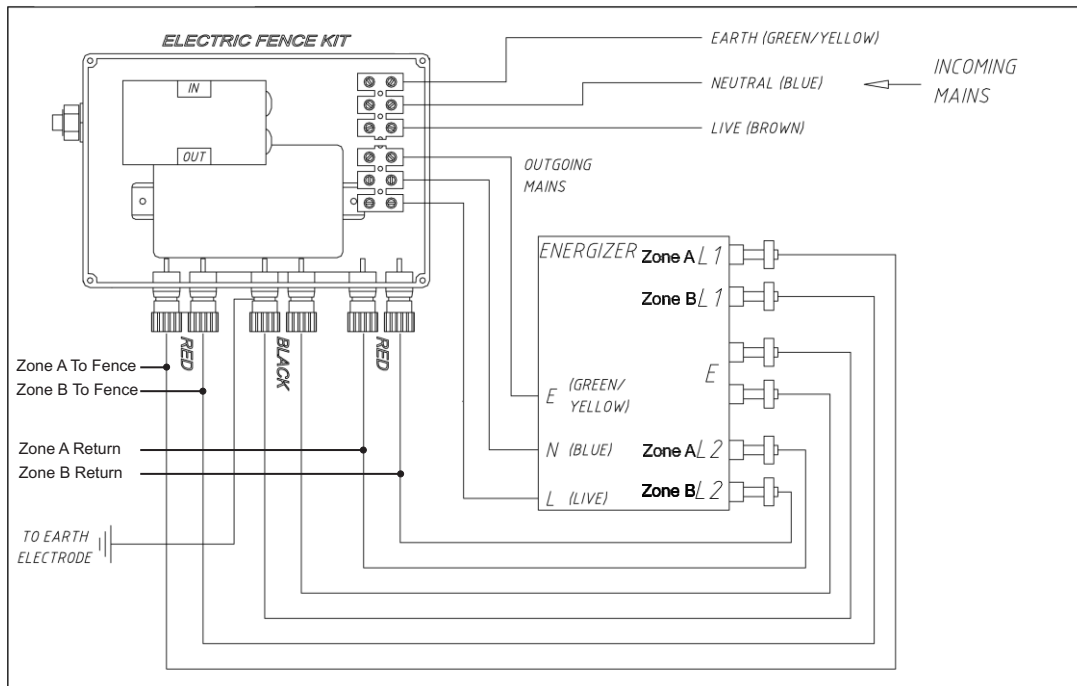

Designed and Manufactured by:

Clearline Protection Systems (Pty) Ltd

385 Roan Crescent Corporate Park North, Old Pta Road,

Midrand, South Africa

P.O. Box 5985, Halfway House, 1685

Tel: +27 (0) 11 848-1100

Fax: +27 (0) 11 314-3880

E-mail: info@clearline.co.za

www.clearline.co.za

